

030-0600
Rotating Catch
Compartment Latch



DESIGNED FOR:

- Single lid or gull wing cross bed tool boxes or similar storage boxes and lockers

FEATURES/BENEFITS:

- Simplified design allows for easy opening and closing force that does not require opening the paddle before closing the lid
- When locking latch is in the locked mode and connected remotely, other latch will be inoperable

Global Locations:

TriMark Corporation
500 Bailey Avenue
P.O. Box 350
New Hampton, Iowa 50659
United States
Tel: 641-394-3188
Fax: 641-394-2392
1-800-447-0343
www.trimarkcorp.com

TriMark Europe
Cedar Court
Walker road
Bardon Hill
Coalville LE67 1TU
United Kingdom
Tel: +44(0)1530 512460
Fax: +44(0)1530 512461
www.trimarkeu.com

TriMark (Xuzhou)
Building A5 Jingwu Road
Xuzhou Economic
Development Zone
Xuzhou, Jiangsu
221004 PR China
Tel: +86 516 8773 0018
Fax: +86 516 8773 0058
www.trimarkcn.com



TriMark. Interactive. Product. Selector



TriMark



TriMark Corporation

AVAILABLE:

- Non-locking or locking versions available with up to 10 different key codes with shuttered keyway
- Two standard mounting hole patterns
- Two-point option
- Optional neoprene foam gasket is available for under the flange of housing
- Supplied cam lock can be packaged unassembled or assembled to the latch with a clip or nut depending on cutout and panel thicknesses

FINISH:

- Black powder coated
- Buffed and polished stainless steel

MATERIAL:

- Housing and paddle: 300 Series Stainless Steel
- Mild steel is also available

INSTALLATION:

- Mounted with 3/16" diameter pop rivets or screws
- Adjustable rod package

Individual part dimensions are for reference only. Refer to individual part drawings for complete dimensions, specifications, and installation procedures. Engineering assistance and application drawings are available.

LOCKING ASSEMBLY SHOWN WITH OFFSET HOOK AND OPTIONAL HOLE PATTERN

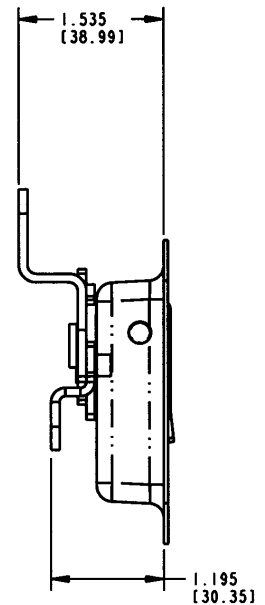
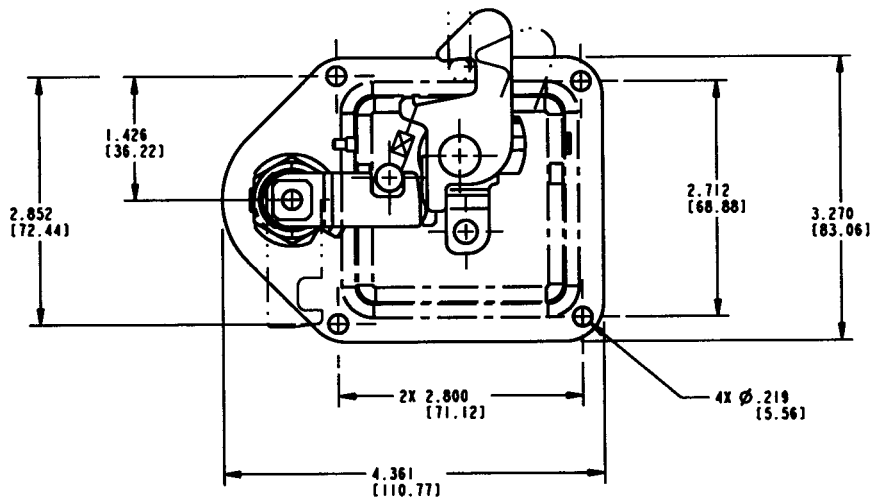

NON-LOCKING ASSEMBLY SHOWN WITH FLAT HOOK AND STANDARD HOLE PATTERN

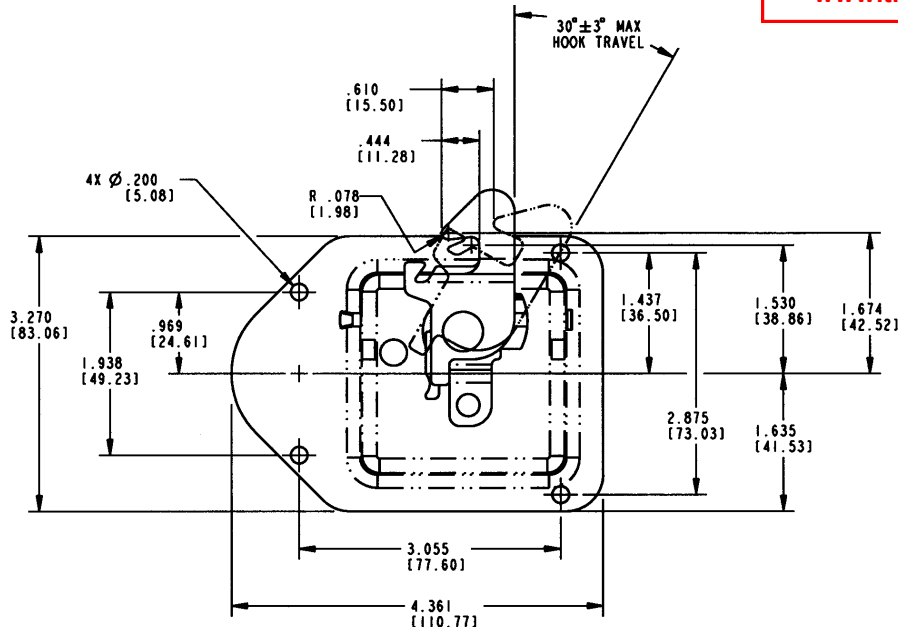

For more information visit
www.trimarkcorp.com

